

Mounting instructions

Alfamacchine Double Miter Saw – Horizontal Clamp Kit

#225120030

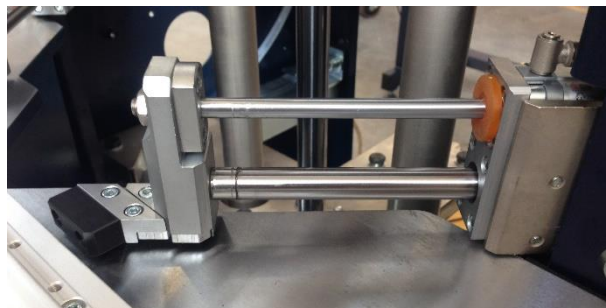

1 – Components list of the mounting Kit #225120030 and Pneumatic Scheme:

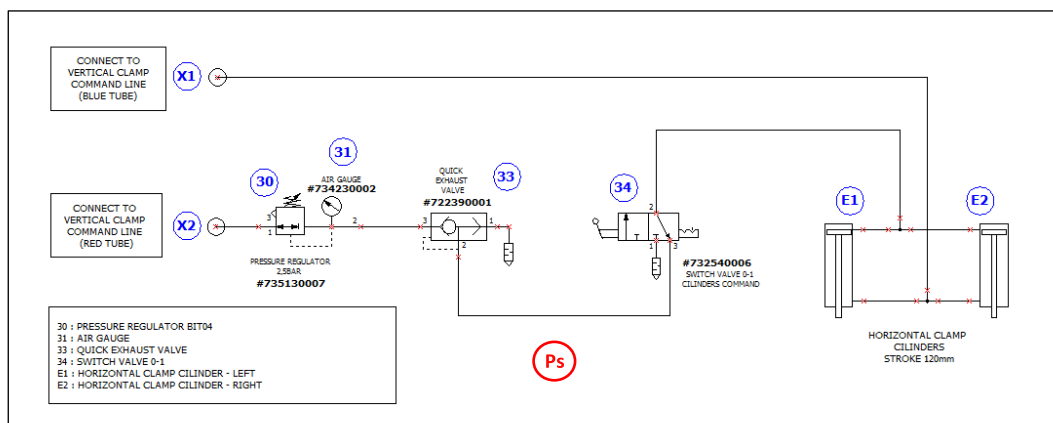
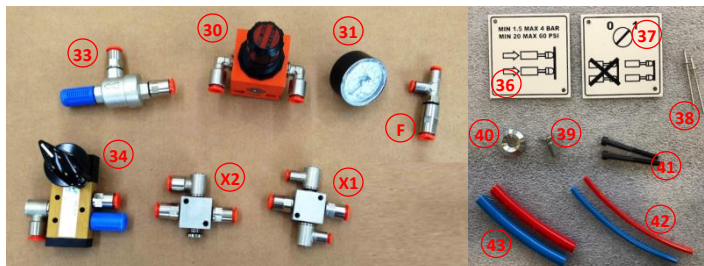

Ref.	Code	Description	Ref.	Code	Description
Ps		Horizontal Clamp Pneumatic scheme.	36	365210817	Air pressure label
E1		Left side Horizontal Clamp;	37	365210815	Horizontal clamp label
E2		Right side Horizontal Clamp;	38	750120001	Rivets 2,5x8
30	735130007	0-4 bar (60 psi) pressure regulator;	39	710200058	TSPEI screw 6x16
31	734230002	Air gauge;	40	336100850	Special washer
33	722390001	Quick exhaust valve;	41	710100012	TCEI screw 4x40
34	732540006	Horizontal Clamp On-Off switch;	42	365110021	red 2,5x4 mm air tubes;
X1		Air collector for the main 6mm "red" tube;	42	365110023	blue 2,5x4 mm air tubes;
X2		Air collector for the main 6mm "blue" tube;	43	365110041	red 6x8 mm air tubes;
F		Air tube fittings size reducer;	43	365110042	blue 6x8 mm air tubes;

2 – Removing the front protection plates:

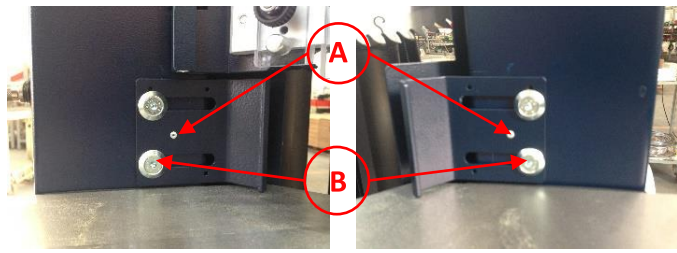

- Drill the two small rivets [A].
- Loosen the 4 screws [B].
- Remove the protection plates.

3 – Cutting the housing for the Horizontal Clamp:



By using a plier, bend and remove the pre-cut corner in both left and right side of the carpentry underneath the front door.

4 – Removing the internal blades protection:



Remove both left and right blades protection.

5 – Breaking the blades protection surface:

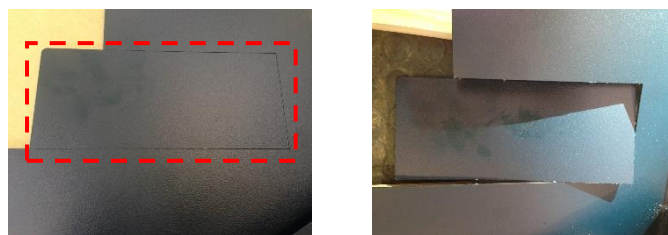

Break the pre-cut surface of the blade protection by hitting on top with a plastic hammer.

6 – Mounting the pneumatic switch:



- break the 22mm diameter pre-cut hole by hitting the part to remove with a punching rod.

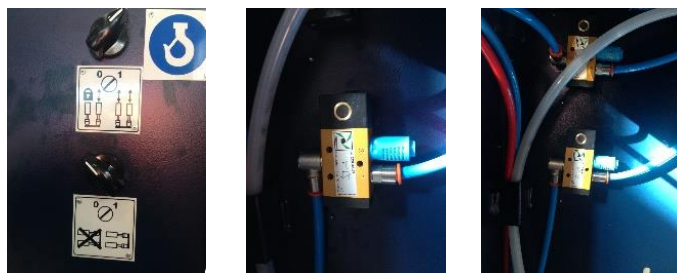

Mount and fix the pneumatic switch valve [34] and its knob.

7 – Mounting the air pressure regulator:



Mount the 4-bar air pressure regulator [30] with gauge [31] to the left side of the saw.

8 – Drilling the fixing holes to the side:

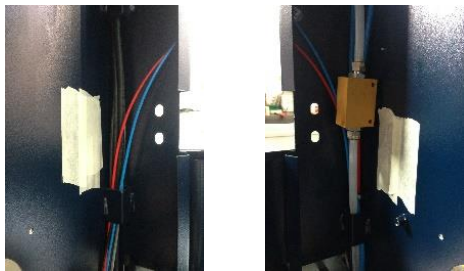

Apply an adhesive paper in the internal side of the body of the saw where the back of the horizontal clamp support has to be fixed.



Partially insert a set screw in the fixing block of the horizontal clamp support.
Pint the set screw with a marking pen.

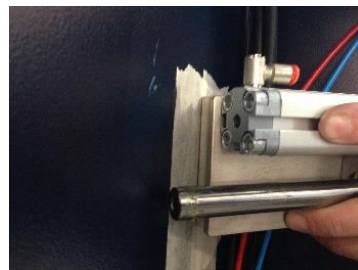
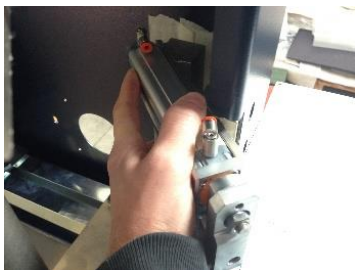

Place the horizontal clamp on top of the working bench and insert it in the internal corner of the saw having the two thread holes matching with the fixing frontal holes of the carpentry.
Press the back of the support having the set screw, previously marked, against the adhesive paper in order to print it.

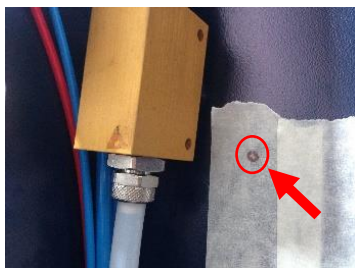

Drill the hole where the paper has been marked from the inside of the body.



Drill the same hole from the outside and make an 8mm diameter size.

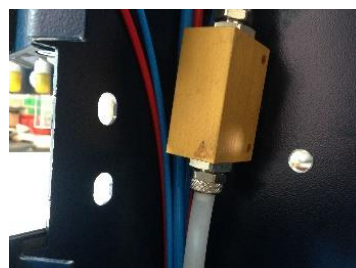
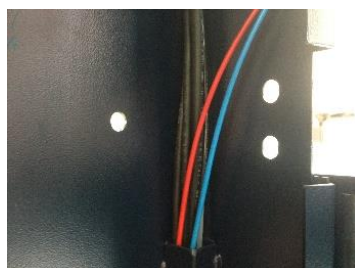

Have the 8mm size hole done in both left and right corner side for fixing the horizontal clamp support.

9 – Mounting the horizontal clamp:

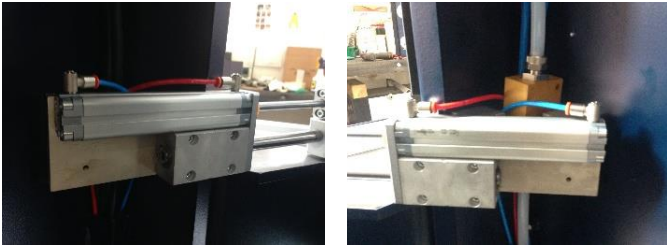

Insert the clamp support [E1-E2] in each corner and fix them by the three 6mm size screws and special washer.



Tighten the screws leaving the clamp at least 1mm above the diagram plates of the working bench.



10 – Modifying the pneumatic plant:

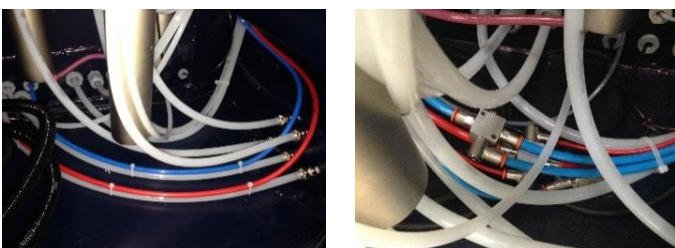

Make reference to the pneumatic scheme “Ps” for cabling the pneumatic plant.

Cut the existing red and blue 6mm size air tubes in the bottom of the saw. These pipes already control the cylinders of the vertical clamp.

Connect the air distributor “X1” between the cut red tube and use the two air fittings 4mm size to connect one side of the horizontal clamp cylinders.

Connect the air distributor “X2” between the cut blue tube and use the third air fitting 6mm size to connect the pressure regulator previously mounted in the left side of the saw.

Connect the output of the same pressure regulator to the air flow, quick exhaust valve and pneumatic switch.

Connect the exit of the switch with a 6mm size tube and have it arriving to the bottom where the other two distributor have been connected (X1-X2).

Connect the air fitting size reducer [F] to the end of the 6mm tube and use the other two 4mm size fitting to connect the cylinders.

It is recommended to have the 4mm size tubes that connect the cylinders at about the same length for not creating movement differences.

